

# PCU-285

## Spiral Viscometer

International standard  
for solder paste viscosity measurement



Printer is optional.

- Measure TI (Thixotropic Index) & R (Viscosity Non-Recovery Rate) according to JIS Z3284.
- Newly-designed Compact Thermostat realizes better workability.
- Touch Panel Display improves usability and visibility.
- Automatic measurement and save data.
- Optional Printer is also available.

## SPECIAL FEATURES

- Malcom Unique Spiral Viscosity Sensor can continuously measure the viscosity and TI of sample having high thixotropy with excellent repeatability.
- Windows system and Touch-panel display Measurement Program Creation and Automatic Measurement. Graph Display of the measurement result is also possible.
- Newly-designed Compact Thermostat realizes better workability, Sensor cleaning at ease, Setup a sample container and etc.
- A mouse and keyboard can connect to the PCU-285.
- The measurement data automatically save in the PCU-285 itself.
- The network system (LAN) unify the management of data from multiple devices.
- USB memory stick can be connected to the PCU-285 to copy data.

Outer Dimensions

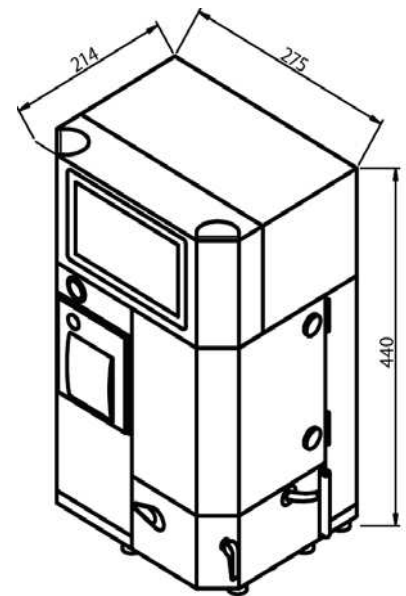

Real Time Graph Display



Sequence Settings

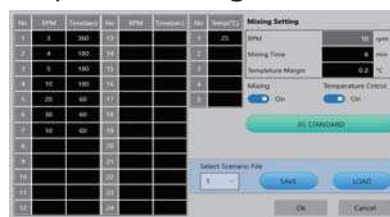

Log Display



Measurement Result Display

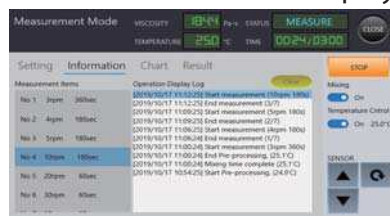

Thermostat



ITEM	SPECIFICATIONS	ITEM	SPECIFICATIONS
Viscosity Sensor	Malcom Spiral-pump type	Display	7 inch Touch Panel
Measurement Range	5Pa.s ~ 800Pa.s	Operation Model	PC connection mode PCU-200 mode Cusom-made program mode
Speed Range (N)	1~50rpm	Built-in Printer (option)	Temp·Viscosity·Shear rate·rpm, Date & Time (* It must be ordered with PCU-285)
Shear Rate (D)	(0.6 x N) s <sup>-1</sup>	Automatic Measurement	JIS Standard method Cusom-made program mode (max. 5) * PC support
Measurement Accuracy	±5% of indicated value	Interface	USB type A x 2: USB flash drive, Keyboard & Mouse use only USB type B x 1: for PC use only LAN port x 1
Speed Accuracy	±2%	Power Supply	AC100~240V 50Hz / 60Hz
Speed Repeatability	±0.5%	Power Consumption	Max. 130W
Temp. Measurement Range	0~50°C	Usage Environment	Temp: 10~40°C Relative Humidity: 10~90% (no condensation)
Temp. Measurement Accuracy	±0.5°C	Outer Dimensions	275 (W) x 215 (D) x 440 (H) mm
Temp. Control Range	15~35°C (±5°C of Room Temp.) Buit-in Thermostat	Weight	Approx. 13.0kg

\* The above specifications are subject to change without notice.

Soldering Process Devices  
LED Manufacturing Devices

Malcom Company Limited  
15-10, Honmachi 4-Chome,  
Tokyo 151-0071 Japan  
Tel: 81-3-3320-5611 Fax: 81-3-3320-5866  
E-mail: whq@malcom.co.jp

Malcom Co., Ltd. Korea Branch  
303 Duri Bldg., 27-3, Gangnam-daero 162-gil,  
Gangnam-gu, Seoul 06028 Korea  
Tel: 82-2-707-2861 Fax: 82-2-707-2863  
E-mail: korea@malcom.co.jp

Representative



Seika Machinery, Inc.  
www.seikausa.com / sfoffice@seikausa.com  
San Francisco Office:  
23785 Cabot Blvd. Suite 306, Hayward CA 94545  
Tel: 510-293-0580, Fax: 510-293-0940