

HIROX
http://www.hirox.com

Think beyond
The KH-7700 Has Arrived
A New Era for Digital Microscopes

Hirox Co.,Ltd. <http://www.hirox.com>
2-15-17 Koenji Minami,Suginami-ku,Tokyo166-0003,Japan
Tel:(+81) 3-3311-9911 Fax:(+81) 3-3311-7722 E-mail:tokyo2@hirox.com

Hirox-USA Inc. <http://www.hirox-usa.com>
1060 Main Street,River Edge,NJ 07661
Tel:(201)342-2600 Fax:(201) 342-7322
Toll-Free:(866)HIROX-US E-mail:inquiry@hirox-usa.com

Hirox China Co.,Ltd. <http://www.hirox.com.cn>
Suite 401, 4/F, Bldg No. 2, No. 358 Guo-Ding Rd.,Shanghai 200433, China.
Tel:+86 21 6564-7772 Fax:+86 21 6510-3393 E-mail:info@hirox.com.cn

Hirox Korea Co.,Ltd. <http://www.hiroxkorea.com>
#603 Acropalace Bldg,1594 Burim-Dong,Dongan-Gu,Anyang-City,
Kyunggi-Do,Korea
Tel:(82-31)385-1130 Fax:(82-31)385-9730 E-mail:bgkim@hiroxkorea.com

Hirox Asia Ltd. <http://www.hirox-asia.com>
Suite 1213, 12/F, Ocean Centre, 5 Canton Road,Tsimshatsui, Kowloon, Hong Kong
Tel:+852 8198-9679 Fax: +852 3015-7657 E-mail:info@hirox-asia.com

Hirox Europe Ltd. <http://www.hirox-europe.com>
8 Place Bellecour 69002 Lyon, France
Tel:+33 8 70 44 59 50 Fax:+33 4 26 23 66 77 E-mail:info@hirox-europe.com

Contact

--

The products in this catalog may be changed at any time, without notice.
PHPO-0710-C786



Creative Progress

The KH-7700 Digital Microscope

Since the invention of the world's first video microscope by Hirox, 20 years ago, we have been constantly developing exclusive innovations and we now stand at the edge of a new era.

As a pioneer, Hirox's mission is to shape a new future for magnified observation and imaging by delivering the ability to "see what could not be seen" and providing an environment where anyone can easily and accurately identify the otherwise undetectable.

A multitude of functions including high-level observation, measurement, analysis, and recording, with straightforward output and report options are effortlessly combined to produce a synergy beyond expectation.

The KH-7700, a digital microscope with a completely new concept in magnified inspection.



1	Unique Concept	
	Extensive Research Leads to Intuitive and User Friendly Functionality	P04
2	Superior Optics	
	Dynamic Observation in True Colors	P06
	Most Complete Range of Unique Optics	P08
	Exclusive 360° Live View of the Sample	P09
3	Revolutionary 3D View	
	Life-like images Achieved through Advanced Video Performance	P10
	Seeing, Recording, Measuring and Analyzing in 3D	P12
	View the Object Fully in Focus	P14
	Variety of Functions for Observing an Object's True Appearance – 3-D Rendering	P15
4	Quick Operation	
	Automated Functions	P16
	Intuitive and Smooth Operation	P18
5	Perfect Image	
	Numerous New Functions to optimize your Work Flow	P20
	Useful Functions that Simplify Image Optimization	P22
	Improving Your Image To Understand Better	P23
6	Advanced Lighting Techniques	
	See the Unseen	P24
7	Different Applications	
	Sample images	P26
8	System Configuration	
	Product Overview	P28
9	User Friendly	
	Magnified Observation Made Even Easier	P30
10	Specification	
	Technical Data Sheet	P31

The standard equipment for the KH-7700 Digital Microscope includes main control unit, a camera, a light source and cable, AC power cable, and a mouse. All other equipment is optional.

PAT: Patent No. 3113375, 3119455, 2512300, 2512299, and 1750384.



1 Unique Concept

Extensive Research into Ease of Use

Extensively developed "user friendly" interface was born out of our desire to provide every user with a comfortable and intuitive environment for observation. After a few minutes working with it, you will never want to go back to working with another microscope again!



Auto Control Brings You Both Improved Accuracy and Easy Operation

The KH-7700 has a multitude of automatic functions such as focus control, multi-focus, and 3D profiling which allow anyone to easily make repeatable observations with greater accuracy. (P. 16). Z-axis auto control frees the user from the sometimes challenging task of focusing and automatically adjusts the Z-axis step size appropriate to the depth of field. Functionality has been designed to comfortably and intuitively speed up observation. The new ACS function (P. 17) automatically selects a calibration value in response to the magnification factor of the lens and automatically adjusts the Z-axis migration length in response to the depth of field.

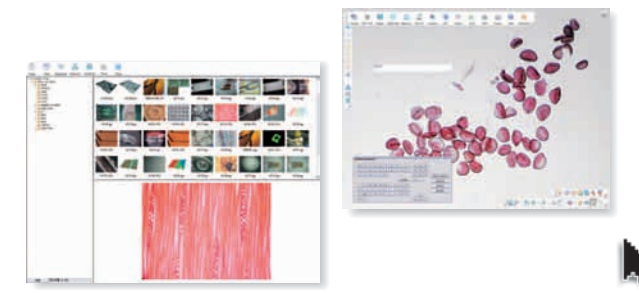

Operation - Easier than Ever!

All the revolutionary functions can be controlled through the user friendly display. The KH-7700, with its many functions and expandability, is the result of extensive ergonomic research. Functionality has been designed to speed up observation comfortably and intuitively. The extensive use of icons and thumbnails in the user interface makes using the KH-7700 so intuitive you'll forget you are operating a digital microscope.



The "User-Friendly" Digital Microscope

The KH-7700 is the realization of Hirox's idea for "easy and comfortable observations for every user." User stress has been reduced and operational efficiency has been improved. By emphasizing ergonomics, we have reduced the burden on the user's body. In short, considerable research has been put into the comfortable use of the digital microscope, meaning that freedom of operation, comfort and enjoyment have been enhanced for this cutting edge digital microscope.

2 Superior Optics

Use the dynamic Observation to know more about your Subject

The true essence of magnified observation lays in the lens and optical illumination characteristics. Specific Hirox lens features, such as the "Long Working Distance (WD)" and "Extended Depth of Field" that push the limits of optical performance to help show the object as it truly is.

Excellent Working Distance (WD) and Depth of Field

The Hirox lenses, featuring "long working distance (WD)", "extended depth of field", and a "high contrast" even at high magnification, are the realization of optimizing the fine balance among competing and often contradictory optical functions and aberrations. High color fidelity, for instance, is made possible by fluorite lenses that are suitable over a wide range of light wavelengths, from ultraviolet up to infrared. Hirox lenses zoom in on the object to show it as it truly is.

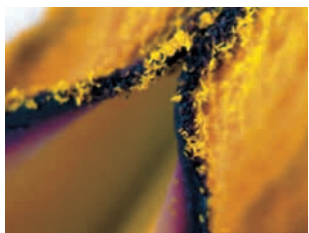

Pollen at 100x [Shallow depth of field]

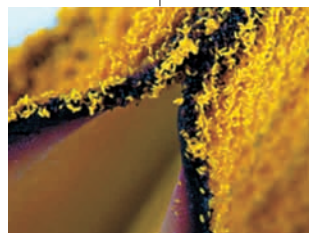

Pollen at 100x [Extended depth of field]

Working Distance (WD)

The 2016 series has a maximum zoom of 160x at 44 mm (WD).
The 5040 series has a maximum zoom of 400x at 54 mm (WD).
The 10C series has a maximum zoom of 7000x at 3.4 mm (WD).

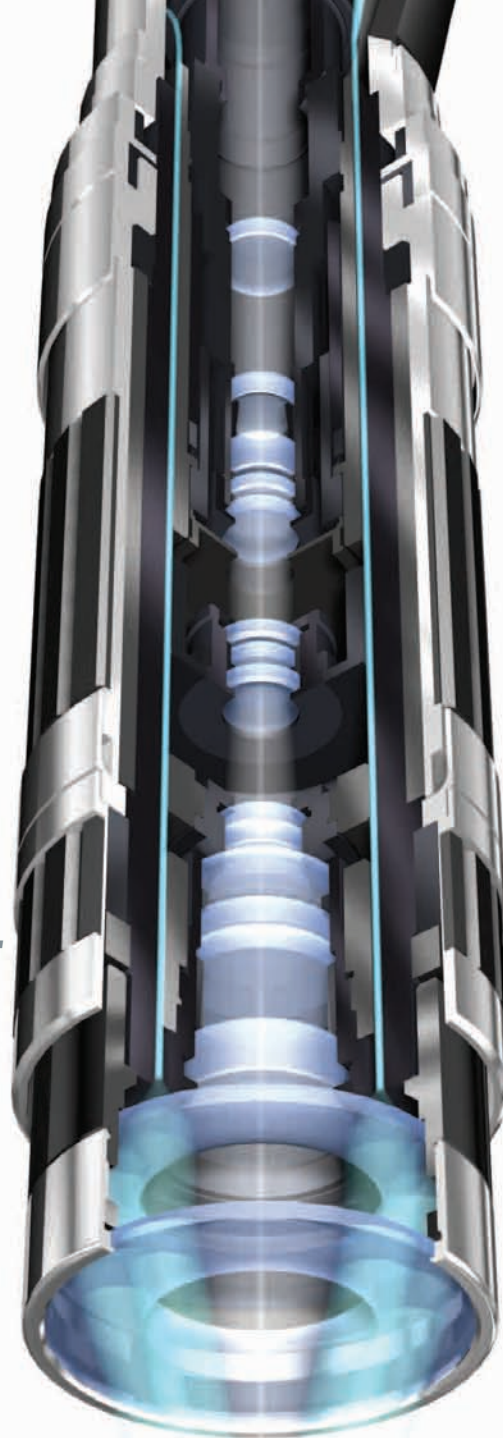

* The illustration is for reference only.

"Hirox Lamp", with an RA of Over 86, Designed Specifically for the KH-7700

To produce a lamp that could achieve accurate color rendering and long life, Hirox worked with the lamp manufacturer, starting from scratch, to design a metal halide arc lamp specifically for the KH-7700. After a year of research, a metal halide lamp was developed with a color rendering index (RA) of over 86 and an average effective life of over 4000 hours.

The higher the performance of a CCD camera, the closer its characteristics of spectral sensitivity are set to the standard of natural light. The Hirox Lamp boasts a color temperature (5460 K) that is very close to natural light. It has a high color rendering index (RA) that makes it the perfect light source for digital microscopy.

The Hirox Lamp has achieved high economic efficiency as well; with an average life expectancy of 4000 hours it destroys the idea that "lamps are consumable products".



Hirox Lamp (60 W metal halide lamp SH-SL7)

Spectral Distribution Graph

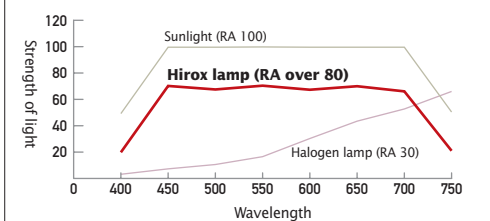

■ RA Value
The RA value is an average color rendering index indicating the quality of the color reproduction by a light source. The color reproduction index uses a color chart to make comparisons with the colors produced by natural light, and the average difference is known as RA. If the color is the same as when viewed with natural light, the RA value is 100. Generally, any value over 80 is considered to have high color reproduction. A halogen lamp with a color temperature of around 3000 K has an RA of only 30 while 60 is already considered as high color reproduction value. Also, even if the color temperature is the same, the appearance of the color may differ depending on the actual spectrum of the light source.

■ High Intensity
Using an energy-efficient 60 W bulb, we achieved a lighting that is significantly brighter than with a 100 W halogen bulb, i.e. the Hirox Lamp produces more lumens per Watt than halogen bulbs.

■ High Color Reproducibility
The bulb has evenly distributed wavelengths in the visible light region and has a color temperature of 5460 K that is extremely close to that of natural light (5000 to 6000 K). Normal halogen bulbs have a color temperature of 3000 K and an RA of between 30 and 60.

■ Stability
We achieved a stable color value by dimming with a stainless iris that does not change the color temperature of the light. This demonstrates excellent performance in terms of lighting flux stability and maintaining color balance.

■ Life Expectancy
The KH-7700 uses a short arc metal halide lamp with an average life expectancy of 4000 hours. The bulb has been calculated to last up to 3 to 4 years without changing when used for 3 to 4 hours per day.

Continuous Optical Zoom

Hirox lenses provide a wide range of magnification with each lens. Greater magnification is achieved by simply exchanging optical adapters.

The extended depth of field provided by Hirox lenses means that as the image is zoomed it creates the feeling that the user is actually entering the object's world.

With a zoom lens that includes ACS functions (P. 17), an optical encoder automatically selects the calibration value as the zoom is changed, updating the magnification saved with the image file as well as the on screen calibration scale.

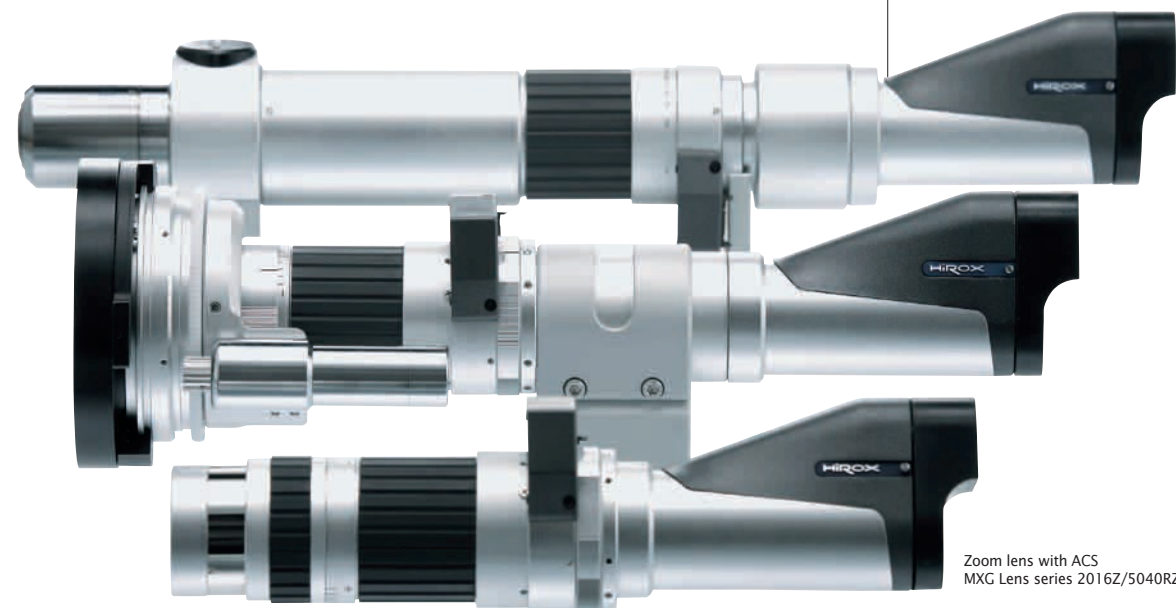

Zoom lens with ACS MXG Lens series 2016Z/5040RZ/10C

2 Superior Optics

"Unique Optics" With Great Zoom and Optical Adapters

As a lens maker, Hirox consults directly with customers to manufacture custom optical systems.

The drive to see the object more clearly through advanced optical technology has resulted in an extensive line of readily interchangeable adapter units that extend the functionality of the lenses.

Extensive Adapter Lineup

No matter how sophisticated the image processing software or hardware becomes the ultimate image quality is determined by the quality of the original image. High resolution lenses coupled with a wide variety of adapters that let you tailor the lighting to give you the brightness and contrast for a specific application means that you are seeing the "objects in their true form". Years of testing and development have resulted in the most extensive line of adapters and lighting control features in the industry.

System to meet Specific Needs

The KH-7700 uses a system unit that meets the user's needs to push performance to the limits.

■ BGA Lens Unit

Using a lens unit specialized for BGA observation with many special functions has made in suit observation possible and does not damage the BGA and solder joints. The optical system has a forward looking, close focus that is usable with a minimum gap of 0.9 mm. The BGA lens can acquire images with BGA as small as 0.2 mm.

<System Configuration>
BGA lens (MX-8GAZ) + BGA stand (ST-BGA) + board holder (A-S-BH)

■ Differential interference lens unit

Rough areas that are normally invisible on flat surfaces are now visible through the use of Differential Interference Contrast (DIC). This method is used in the field of LCD research to detect electrode impressions.

<System Configuration>
Differential interference lens (MX-180DIL) + ST-HU series stand

■ Variable transmission light unit

High contrast and vivid images of microbes can be observed using transmission differential interference (DIC) lighting. Elevated observation is possible by moving the phase difference filter.

<System Configuration>
Variable transmission illumination unit (AS-DFR) + co-axial 10x zoom lens (MX-10C with objective lens) + ST-HU series stand

■ Crystal transmission unit

Polarized light makes it possible to see the refraction and structural orientation of (comparatively large) transparent samples, which would not be visible using normal light.

<System Configuration>
Crystal transmission unit (AS-BP) + MX-10C (with objective lens) + ST-HU series stand



Observe Every Edge Without Missing a Spot

The patented dynamic rotary head overcomes the limits of observation from a fixed point of view and allows shapes to be fully understood. The motion results in kineopsis and gives the observer the feeling of holding the object in his own hand. Also, it allows easy video image observation of even large objects. An image of the entire object can be accurately acquired, allowing 3D observations in real-time.

*The illustration is for reference only.

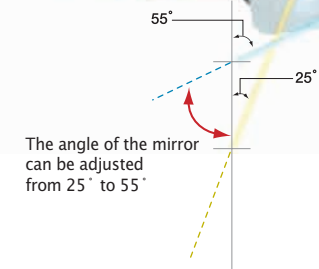

A 360° Field of View

The 360° world of the object is now easily accessible, allowing you to inspect the object dynamically as if you were simply walking around it. The elegant mechanical design takes advantage of vision physiology to give the user a true image of the object.

Rotary Head

Until now, it was common to tilt the lens or rotate the object, limiting observations of micro- and macro-sized objects. But changing the observation angle makes it very difficult not to lose the focus point, especially during observations at high magnification.

Simply connecting the rotary head adapter to the zoom lens allows observations of the conditions of the sides of the object without missing a spot. The forms of complex objects such as the surfaces of spheres and powders, the profile of electronic parts, and cells can now be observed in a small space and in 3D without rotating the lens itself and without adjusting the focus.

The KH-7700 uses mirrors that have been tested to high level standards to reflect colors within a fraction of a degree of actual colors. The core accuracy of the optical system rotation has extremely high accuracy in relation to the optical axis. The extended depth of field, a dynamic mechanism, and the high video rate are the combination of special patented Hirox technologies.

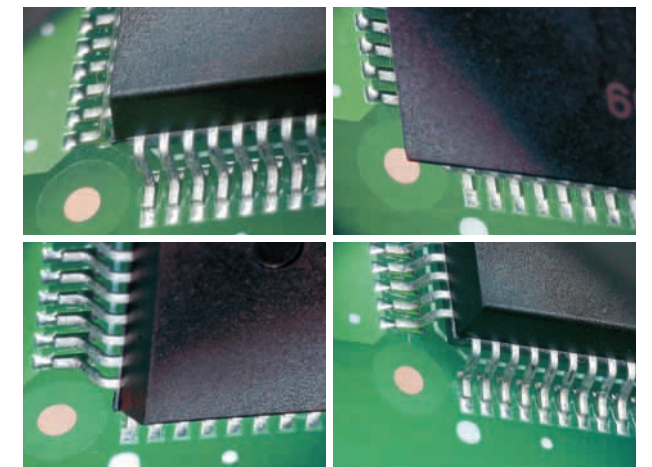

QFP Contacts at 30x (45° point of observation angle)
[Conditions of solder application]

Easy Control of Angle and the Direction and Speed of Rotation

By moving the 360° rotating prism 25° to 55° vertically, it is possible to acquire a wide range of views of the object. The rotational direction and the rotational speed are easily controlled with the press of a single button. Also, with the 5040 series lens, the rotary head adapter is attached with one touch. The adapters can be switched with only one hand, making the change from 2D to 3D instantaneous.

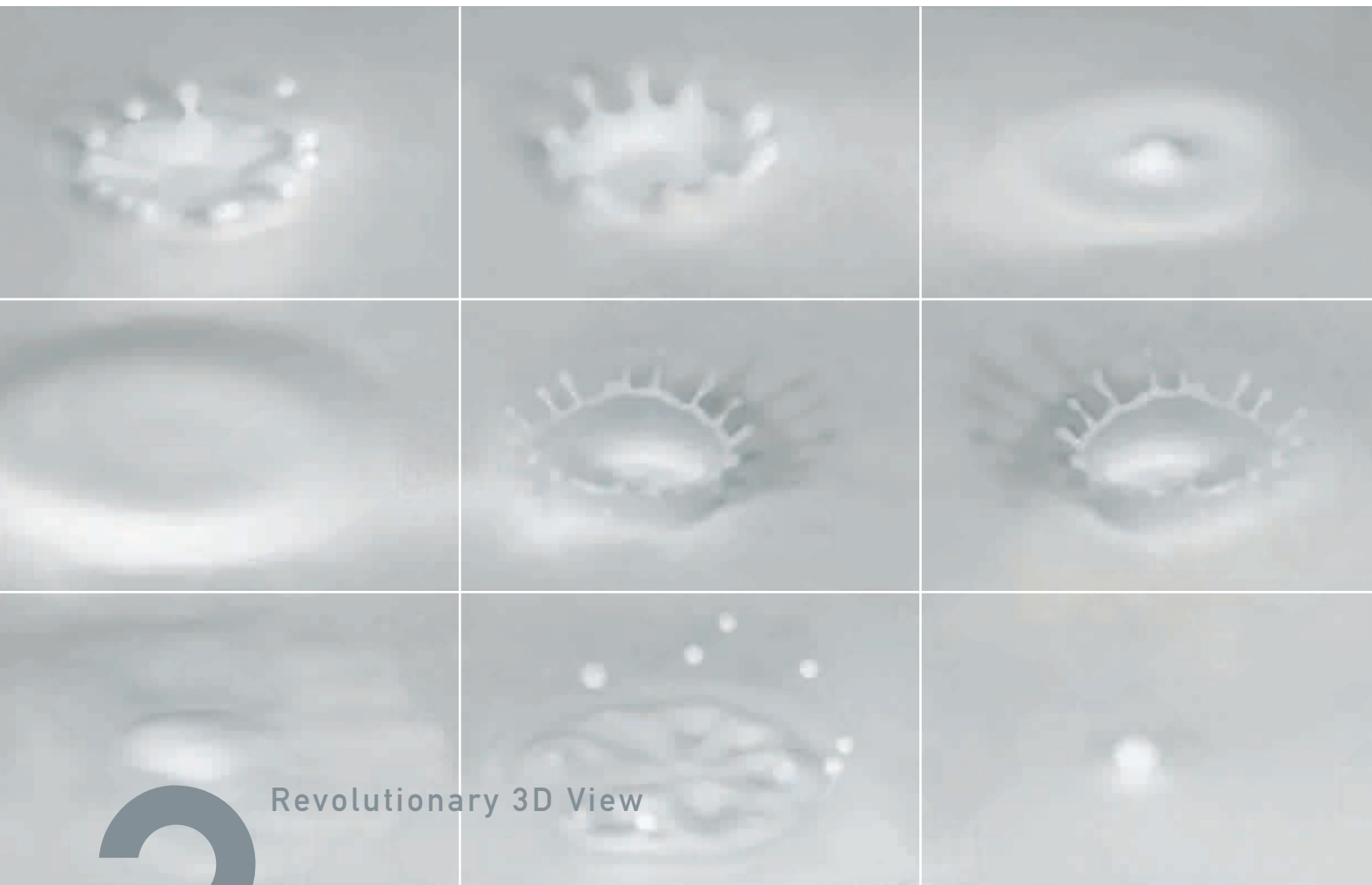

3

Revolutionary 3D View

* The photo is for reference only.

Live Inspection through Advanced Video Image Performance

Never missing a frame, trackable video images are produced without image lag or motion artifacts. Revolutionary video image performance from Hirox provides extremely lifelike images.

Smooth Live Images Provide Realistic Video Observation

There is information that cannot be obtained about the entire object using only still pictures. In order to obtain this information, video observation is necessary. Live images of jerky movements cannot be called video. Only video performance in the pursuit of reality produces extremely natural observations.



30 f/s-equivalent Real-time Video with Double Buffering

To output an image to the monitor in real time, video performance needs high-definition reproduction and accurate output of the live image. Disturbances in live images signify a long period of video observation and difficulty obtaining the point of view. A frame rate that realizes "stressless video observation", as if viewing with the naked eye, is the result of extensive research and development which has led to dramatic improvements in the trackability of images. We have exceeded the previous image output limit of 15 f/s. The combination of high-definition images and realism is realized by a double flip method (DFM), a newly developed custom IC that provides 30 f/s image output.

Excellent video performance allows you to find, measure, profile, and observe a point in real time in 360 degrees with the rotary head.

Double Flip Method (DFM)

DFM mode allows real image output by writing high-definition images to two memories.

Playback in UXGA Progressive Mode

By scanning in progressive mode, images are vividly output without flickering to a UXGA high-resolution monitor.

Operations such as focusing, zooming, moving the object, and video recording can be performed without afterimages or color divergence.

Progressive mode

Progressive mode refers to a single image or frame being scanned in one pass. This mode curbs flickering and halation present in interlace mode.



Equipped with a 160 GB Hard Disk

In addition to being able to save high-resolution images on the spot, the 160 GB hard disk makes it easy to save video. You can use the timer to record time-lapse images over long periods of time and use the rotary head to record video in 360 degrees to capture every angle. Saved high resolution images can also be written to any media at hand, including CDs, DVDs, and USB memory devices.

3 Revolutionary 3D View

Taking Pictures, Measuring and Analyzing in 3D

With various display formats and rich 3D measuring functions you'll see things you've never seen before in a 3D format. Without missing a single spot, extract easily the 3D information of your sample.

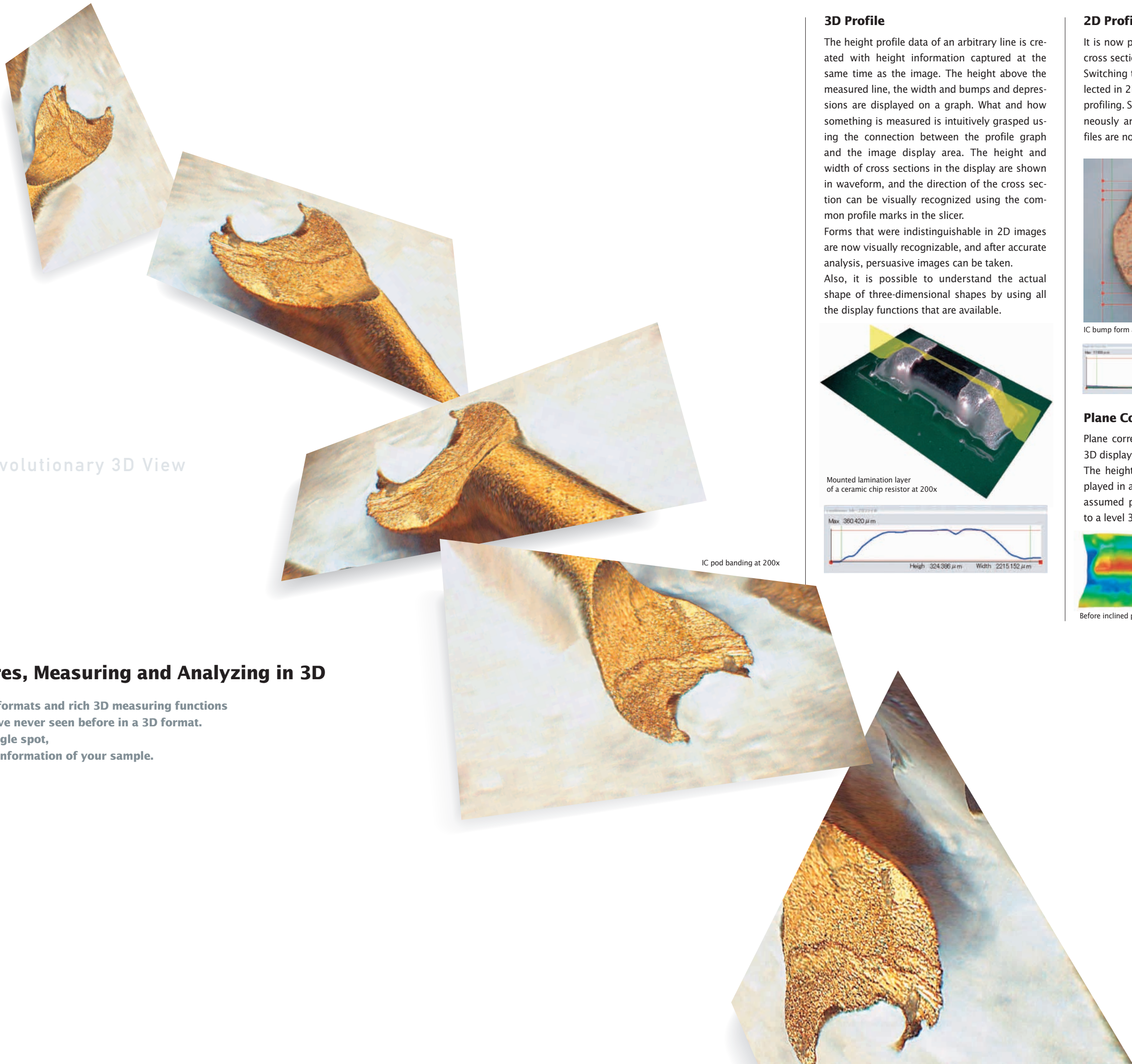

IC pod banding at 200x

3D Profile

The height profile data of an arbitrary line is created with height information captured at the same time as the image. The height above the measured line, the width and bumps and depressions are displayed on a graph. What and how something is measured is intuitively grasped using the connection between the profile graph and the image display area. The height and width of cross sections in the display are shown in waveform, and the direction of the cross section can be visually recognized using the common profile marks in the slicer. Forms that were indistinguishable in 2D images are now visually recognizable, and after accurate analysis, persuasive images can be taken. Also, it is possible to understand the actual shape of three-dimensional shapes by using all the display functions that are available.

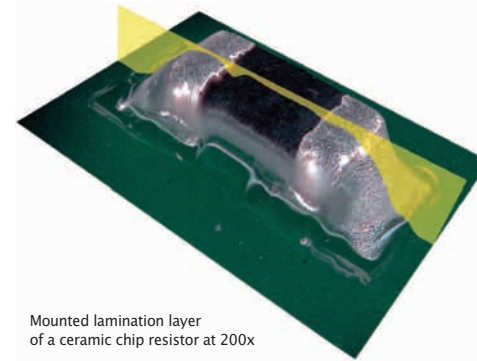

Mounted lamination layer of a ceramic chip resistor at 200x

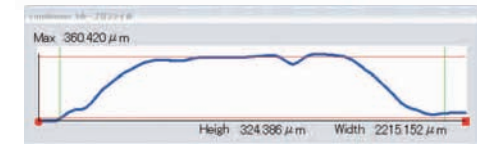

2D Profile

It is now possible to measure profiles of vertical cross sections of an object. Switching to 3D profiling is smooth, as a line selected in 2D profiling can be moved as-is into 3D profiling. Set multiple measurement lines simultaneously and comparisons of cross section profiles are now even easier.

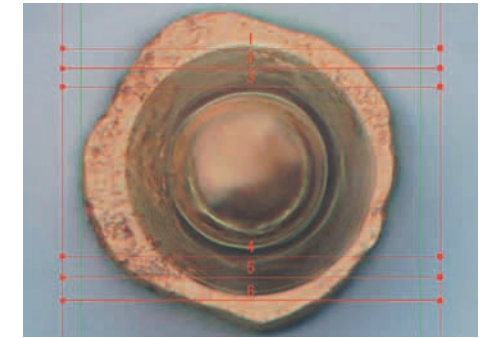

IC bump form at 2000x

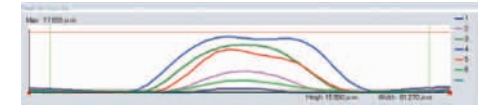

Plane Correction

Plane correction corrects inclined planes on the 3D display so they are leveled. The height difference of inclined objects is displayed in a false color window. Simply indicating assumed plane points with the mouse changes to a level 3D display.

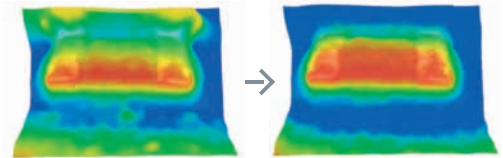

Before inclined plane correction

After inclined plane correction

* The photo is for reference only.

Multi-focus 3D Synthesis

It is possible to synthesize all-in-focus images, even for rough objects, by capturing slices of the image. Detailed settings are possible for the captured height position of the image. By simply specifying the number of captured slices, depth synthesis is possible on a large UXGA screen. Selecting synthesis settings for fully automatic synthesis, semi-automatic synthesis, manual synthesis, synthesis speed, synthesis type, and synthesis form allows selection of the most appropriate method of synthesis for difficult object forms and various observation environments. Highly accurate depth synthesis is possible without burdensome focusing through use of the Z-axis auto control.

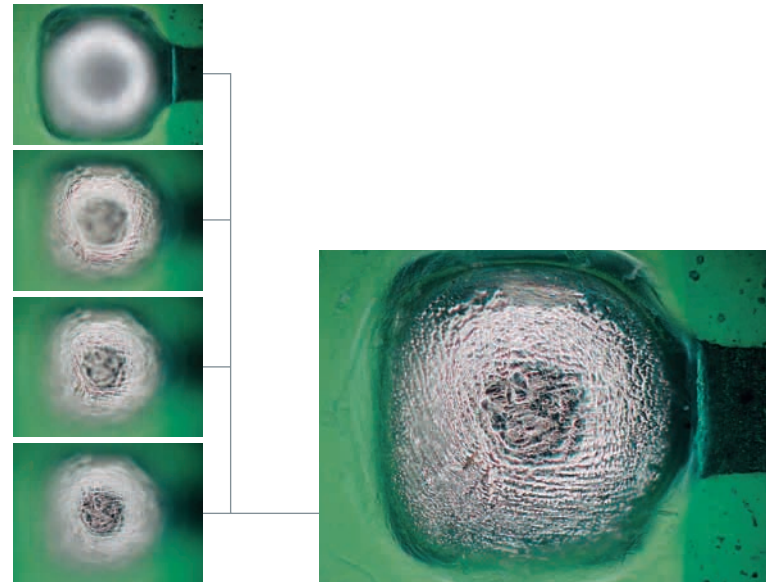

Solder for a base mounted pad at 400x
[Image synthesis display]

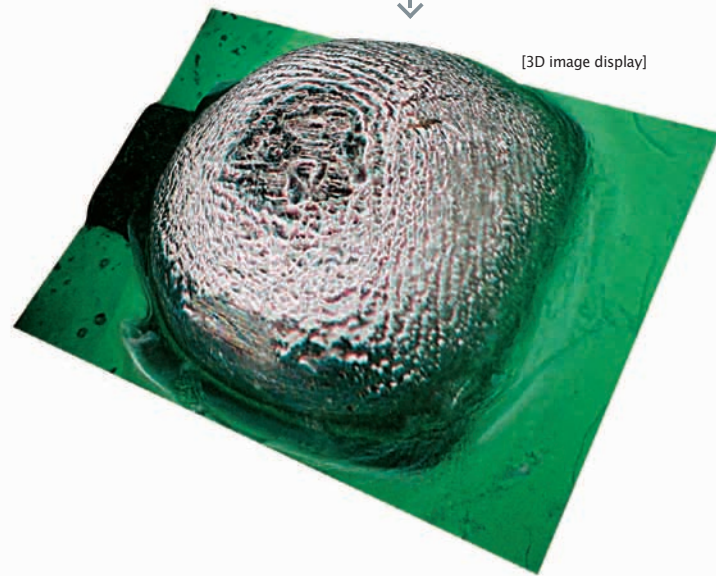

[3D image display]

3 Revolutionary 3D View

View the Object Completely In Focus

High precision image synthesizing technology is used to acquire the surface information of an object with its hills and valleys. Accurate and efficient observations are possible with the auto 3D synthesis.

Auto Alignment

By placing a check mark during multi-focus 3D synthesis, synthesized images are automatically corrected when a disparity occurs in the view range while changing the focus height depending on the environmental conditions. During the 3D synthesis process, auto alignment compares image data at specified matching points, calculates misalignment, and corrects as required. Adjust the accuracy of corrections by selecting the number of matches and the matching position.

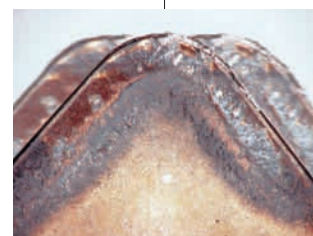

Bite cut at 60x
[Before auto alignment]

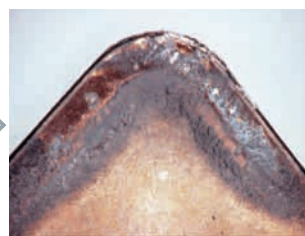

Bite cut at 60x
[After auto alignment]

Measuring Point Height

Real-time height is displayed by simply moving the mouse over the arbitrary line position on the 2D screen. With one click it is possible to paste, just like a memo, a label with the measurement. The measurement list pallet is automatically displayed and can be edited. Easily create images for reports in addition to being able to simply measure the height of numerous points.

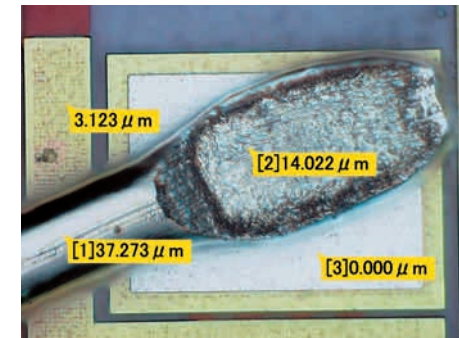
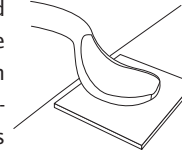

IC pad bonding at 2500x

Measuring Volume and Area

For area and volume measurements, an object is sliced horizontally at any height and the area of a specified cross section and the volume above (or below) can be obtained. Because the measurement range is displayed in color, area and volume are measured while verifying the image of the measurement range on the screen.

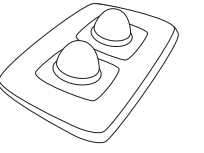

0402 laminated ceramic pad at 200x

Variety of Functions for Observing an Object's True 3D Appearance

2D images may hide countless details of the object. Multiple 3D rendering and measuring functions allow extremely detailed observations.

Versatile 3D Display

A multitude of 3D display methods are available. Object information that was previously overlooked is now obtainable with versatile display methods such as a wire frame display for viewing the form from off-side angles, a false color display for clearly showing the elevation of an object indiscernible from above in rainbow display, and a coordinate axis display.

IC bump at 2000x
[Texture display]

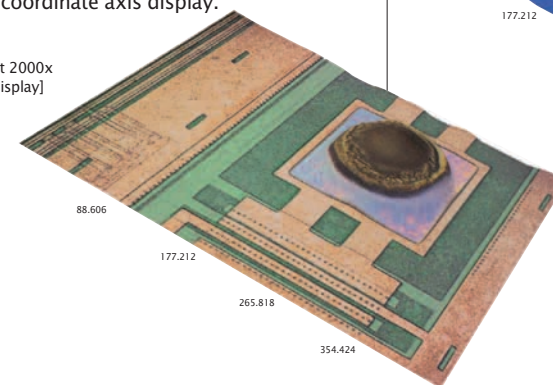

IC bump at 2000x
[False color display]

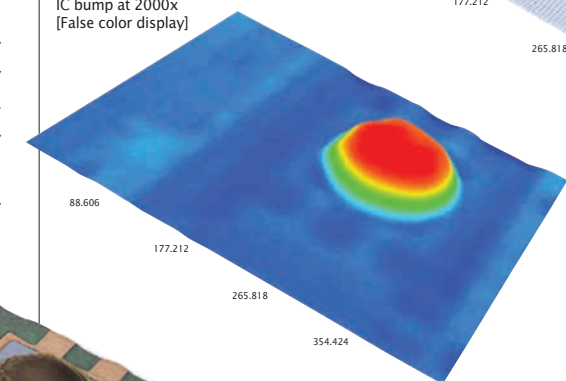

IC bump at 2000x
[Wire frame display]

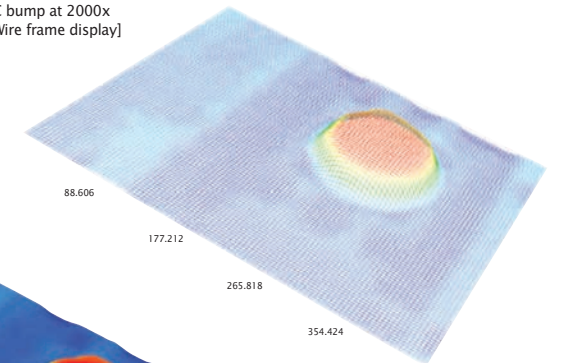

4 Quick Operation

Automated Functions

We have successfully synchronized the three cutting-edge technologies, AMF3D Synthesis Function (auto multi-focus 3D synthesis function), APS Function (auto positioning function), and ACS Function (auto calibration selection function) to seamlessly generated accurate 3-D images.

Focus Control, Observation, Measurement, Analysis, and Data Management Are All Seamlessly Connected

The KH-7700 system integrates a fully automatic focusing system necessary for magnified observation.

Standard auto focus, measuring functions, multi-focus 3D synthesis, 3D and 2D profile synthesis, point height measuring, area and volume measuring functions and others are integrated so that they can be used simultaneously without stopping your work.

Also, the ACS function automatically selects the calibration and puts the lens, Z-axis and controller all in the hands of the user via a mouse. From changing the zoom to Z-axis measurement to focus control, it's no longer necessary to perform each function individually. Extensively researched auto functions make magnified observation even more effective.

"Real-time Focus Search" with the Z-axis Monitor

The pallet display of the Z-axis control monitor makes focus control even easier. The Z-axis can not only be verified at a glance, but focus control is performed with the mouse. The focus point is automatically recorded while moving the Z-axis. One click instantaneously moves to the point of focus. In addition to adjusting the focus even at high magnification, the bottom limit button is used to set the bottom limit of Z-axis movement (APS function). Returning with one click to the "bottom limit", "base position", "arbitrary memory point", and moving from the auto focus to the Z-axis operations are all available on the pallet. Smooth connection through the Z-axis control monitor significantly improves observation efficiency and intuitive operability.

Connection of Mouse Operations and Focus Block

Simply moving the mouse wheel controls both the Z-axis and focus. This makes fine adjustments in micrometers possible, which were previously difficult to perform manually (1 notch of the mouse wheel / $0.25\mu\text{m}$). Operations previously conducted manually are now completely in the palm of the user's hand. While watching the monitor and moving the mouse, zooming and specifying a focus area, synthesis and analysis can now be performed as desired. Try our stress-free observation, achieved through intuitive operations for yourself!. A special controller and manual adjustment can be concurrently performed, widening the breadth of work to match the environment.

No More Mistakes with the "ACS Function"

The lens comes standard with the smallest high sensitivity sensor in its class. Calibration values are automatically selected while zooming and this reliably prevents incorrect selections of calibration values during image measuring and recording (ACS function).

Problems like "I measured but the calibration values were incorrect" no longer occur with the ACS function.

Also, the Z-axis movement speed is automatically optimized in response to the lens's depth of field and the zoom. Because the movement speed is automatically adjusted at high magnification, focusing and verification is even smoother. When using multi-focus, the guide function is

enabled to automatically set the number of synthesized shots based on the lens's magnification and the subject's depth of field. It is no longer necessary to perform burdensome step-by-step operations for advanced observations. Accurate and vivid observations are achieved effortlessly with the ACS function.

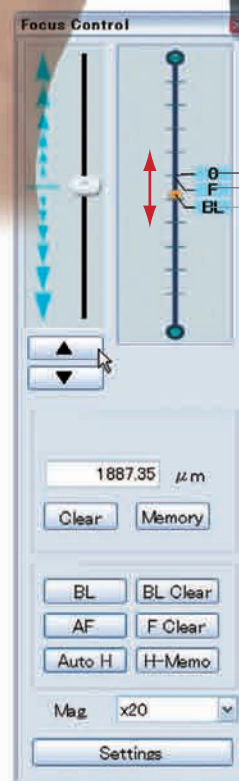

Improved User Interface Makes Extensive Functions Easy to Use

The KH-7700, boasting a multitude of functions and expandability, is the result of extensive research into ease of use. It is filled with functions that have decreased the time needed to make observations and provide stress-free operability. Intuitively performing operations as desired allows anyone to effortlessly use the many advanced functions.

4 Quick Operation

Intuitive and Smooth Operation

The KH-7700 uses an advanced operating system with a visual navigation system designed from the ground up so any user can easily become a master of magnified observation.



Print by Simply Connecting to a Printer

Directly connecting to a PictBridge compatible printer with a USB cable allows printing directly to a printer without using a computer. Observation data and reports can quickly and easily be created without the need for sending data to a computer or using application software. Putting the data on paper is easy, dramatically increasing the effectiveness of image adjustment and data reviews.

"Library Preview" for Managing Saved Images

Saved photos and videos are displayed in a list on the library screen. Speedy verification of saved images is made possible with thumbnails (small photos). Photos, videos and 3D images can all be previewed. The desired images can be found quickly even from among similar images. Operations such as creating new folders to classify images, writing to CD/DVD, connecting to a network, and copying to USB memory devices or other external storage devices can all be performed together while visually verifying images in the library.

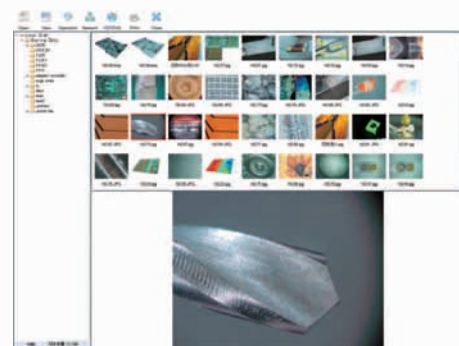

Library Preview of a drilling tool at 200x

Optimal Corrections and Easy Adjustments with "Camera Preview"

Use this function to simply select and adjust camera setup patterns while viewing preview images. There are two ways of previewing images. "Camera Preview" combines gamma, edge and color correction to automatically display 8 types of images. "Detailed Camera Preview" displays images after adjusting for each correction. Optimal image adjustments can now be made without the use of complicated image editing software.

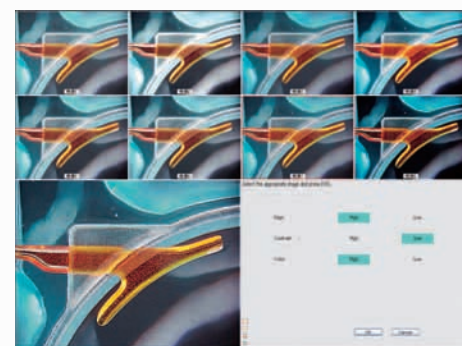

Selecting the best image using the Camera Preview

"Real-time Zoom" with the Mouse Wheel

This function allows free zooming by simply rotating the mouse wheel without changing the lens magnification or the lens. Through the use of an independent digital image processing algorithm, the observation point can be enlarged while maintaining the depth of field. Also the entire image can be moved horizontally in real-time in the navigation window. Even if the observation point is lost during high magnification, it can be quickly reacquired.

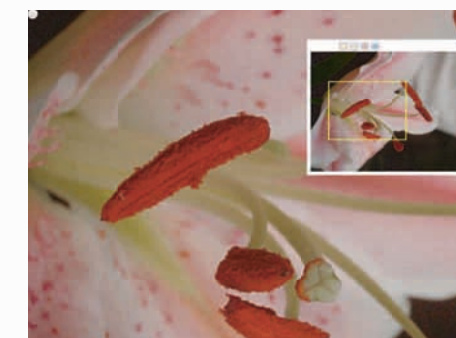

A lily taken at macro

Place Icons on a "Custom Menu"

Place up to 20 of the most frequently used menu icons, chosen from among the multitude of functions, on a custom menu bar. This saves time searching for functions from the full menu and allows for arranging icons in the same order as operations are performed. The menu bar can also become an icon so that it does not interfere with observations.



"Gigabit Ethernet" and "6 USB 2.0 Ports"

The KH-7700 uses high-speed gigabit Ethernet to connect to various devices. It is markedly faster when compared with standard LAN. High resolution images are sent effortlessly. Expandability for connecting peripheral devices is high with the inclusion of 6 USB 2.0 ports. Even if a keyboard, mouse and a printer are connected, there are still extra USB ports. The standard 6 USB ports adequately support devices for expansion.

5 Perfect Image

Numerous New Functions are the Answers to Your Highest Expectations

By asking users what functions would truly be useful, we have developed new functions that extend the usefulness and power of the imaging system.

"Handy Synthesis" for Synthesizing All-In-Focus Images as Desired

Easily synthesize focused images of the entire object by manually rotating the standard dial to raise and lower the lens.

Operational advice is displayed in an easy-to-understand way throughout the synthesizing process. All you need to do, in order to create a high quality synthesis, is to rotate the dial to match the timing shown in the animated instructions.

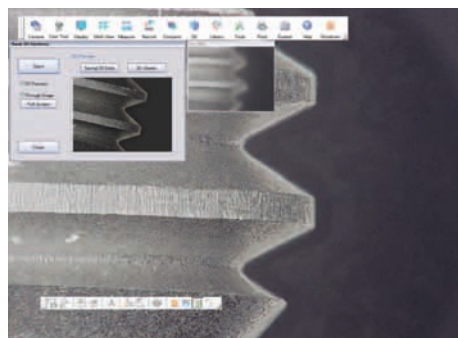

T screws at 60x



Capture High Resolution Images at 30 Megapixels

Select from various resolutions (4/8/16/30 megapixels) to match the type of observation. Using the appropriate file size saves time and money.

Our unique digital technology is able to eliminate unwanted noise without degrading the image. This makes it possible to produce high resolution images up to 6400 x 4800 pixels. Images saved at an equivalent of 30 mega pixels show the finest detail in richly textured reproductions.

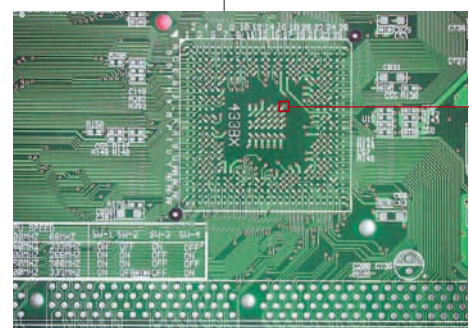

LCD monitor board taken in macro mode

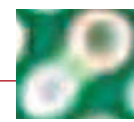

LCD monitor board captured at 30 megapixels (enlarged section)

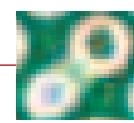

LCD monitor board captured at 2 megapixels (enlarged section)

Quickly Create Documents with the "Easy Report Creation Function"

Use the easy report function to freely create documents with images, image information, measurements, comments and diagrams.

It is possible to save previously created documents as templates. Connect via USB to a Pict-Bridge compatible printer to directly print documents without a PC. Since the user can create documents without interrupting the measurement and observation process, this function is useful not only for creating documents, but also for creating memos while working and as a tool for creating instructions.

Image Information is Automatically Saved to a File

When the image is saved, information such as the camera settings and the date and time are automatically recorded in the JPEG (.jpg) file. This allows brightness, shutter speed, gain, white balance and other aspects to be verified at any time from the saved image. It's even easy to attach image information to documents created using the report creation function.

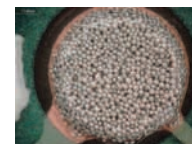

Cream solder at 300x

Camera Settings	
Shutter Speed	1/8000
Gain	U (0)
White Balance	R74 B52
Camera Auto Contrast	2
Fluor	4
Filter Size	2x3
Edge Level	7

Image Information

[Image and image information automatically saved to JPEG file]



Image Information Settings display

"Image Comparison Function" Automatically Evaluates Differences

With our newly developed image handling engine, the differences between two similar objects can be automatically evaluated. Where and how much of the desired part is detected, the image difference and the surface area are automatically evaluated.

For example, record an image of a "good" object and compare it with another object while detecting dirt, defects, foreign bodies, and scratches. Then, record still images and create reports using the compared images.

Contribute to the reliability and efficiency of testing by placing the evaluation results in a data base to easily compare evaluations of good and defective products.



Ancient sculpted ivory jewel at 20x

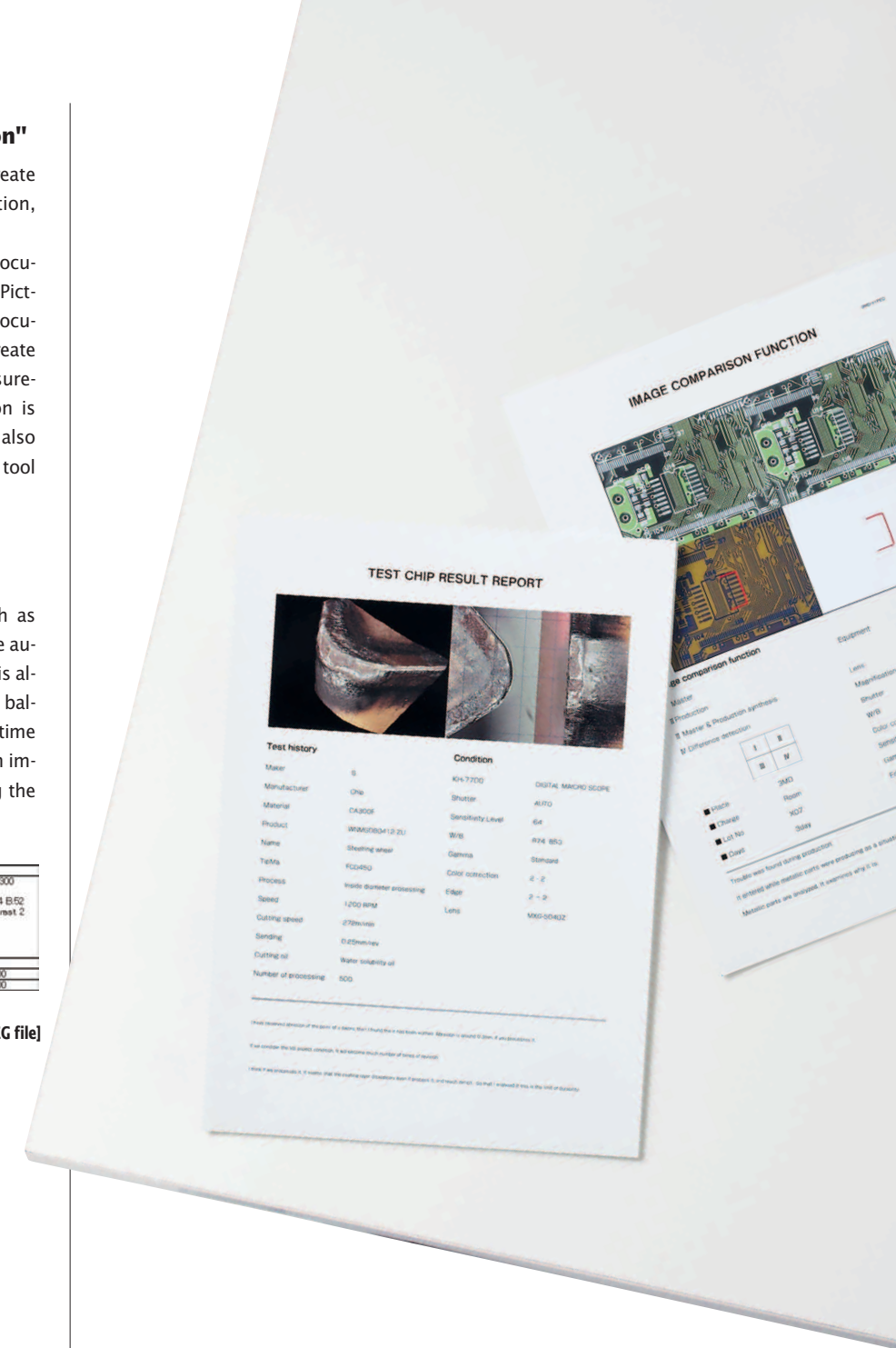

5 Perfect Image

Useful Functions that Simplify Image Optimization

Obtaining optimal observation results does not require time-consuming procedures. Desired results are achieved quickly using highly accurate and time-saving functions.

The Camera has Evolved using the New Back Focus Ring

Quickly change between moving and fixing the back focus ring by loosening the pin with the tip of your finger.

While high accuracy measurements are possible by fixing the back focus, moving the back focus creates a wide-angle lens.

Also, handle various lighting by attaching a fiber optic cable. It is now unnecessary to replace the fiber optic cable when changing the lenses.

Simply inserting a fiber optic cable can immediately begin the next observation. Operability is increased and compact storage is possible because a special fiber optic cable is unnecessary.



Capturing with Anti-Halation

Halation occurs with metals, glass, solder, mirrored surfaces and other highly reflective objects that reflect strong light into the lens and cause white blurring.

The KH-7700 captures images and eliminates halation with one click, significantly reducing the time needed to adjust the lighting.

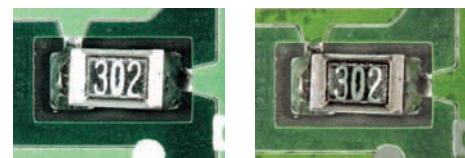

Chip resistor at 50x
[Normal image]

Chip resistor at 50x
[Image captured with anti-halation]

Extensive Measurement Functions

Measurements including length, surface area, and angles can be taken in various styles. With a single mouse operation, the object on-screen can be measured in real-time.

In addition to the actual dimensions, the measurements results can also be shown as a percentage of a previously selected reference value. Both auto and manual height measurement are possible and a wide variety of measurements are set for the object.

Also, the measurement list data can be saved to a CSV file which can be further used on a computer with any common spreadsheet program.

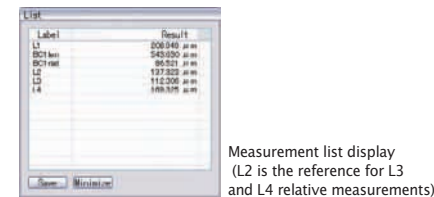
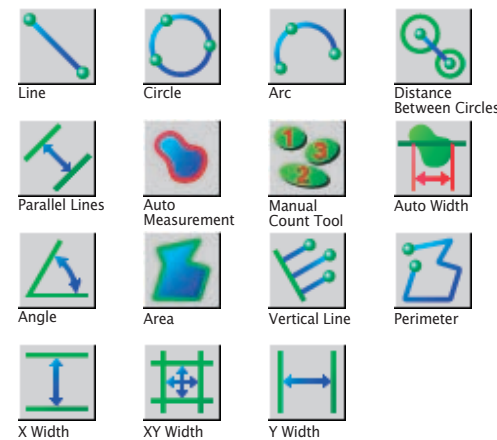

Measurement list display
(L2 is the reference for L3 and L4 relative measurements)

High Accuracy "Binarization" Display

Image brightness and RGB values are evaluated so you can display a binarized image.

The threshold can be adjusted while verifying in real-time in full screen and noise in the binary display is easily eliminated by adjusting the area level settings.

Advanced Image Adjustment Functions

Desired adjustments are made with a single click, allowing for image optimization without specialized knowledge.

Features Prominently Shown in 3D with the "Lighting Function"

Use this function to manipulate the data lighting to enhance the 3D image.

Display the optimal image for the task by freely changing the direction of lighting. This function is effective for observing rough surface in 3D.

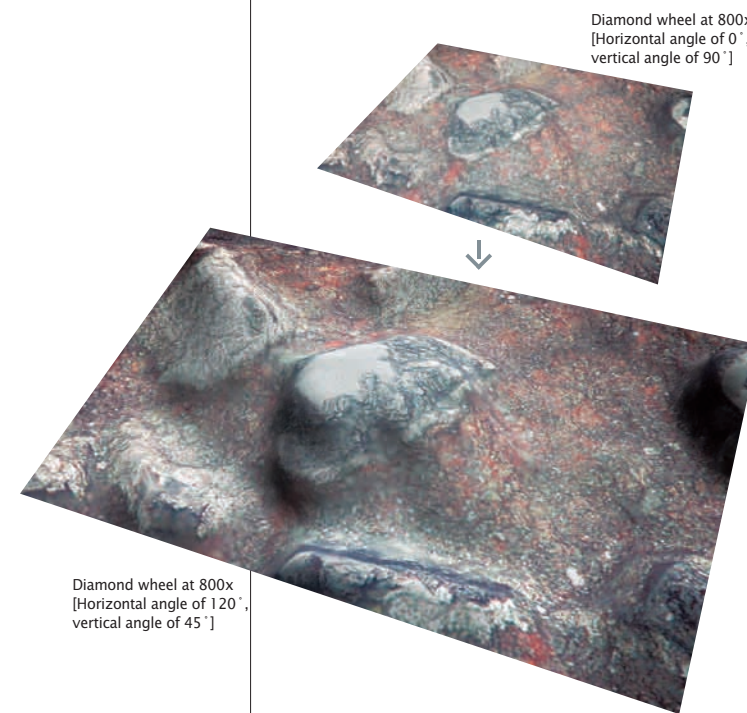

Diamond wheel at 800x
[Horizontal angle of 0°, vertical angle of 90°]

Diamond wheel at 800x
[Horizontal angle of 120°, vertical angle of 45°]

Adjust Contrast

Adjust contrast is effective for objects with little difference in shading. Verify and make adjustments while previewing the image contrast.

Strengthen Edges

Use this function to detect image borders and emphasize the borders between light and dark when sharpening the edges of images with a shallow depth and emphasizing scratches.

Four levels of settings are pre-configured and can be used specifically on defined points in the area.

Noise Removal

Reduce noise leaving the edges as-is to decrease the graininess of the image.

Four levels of settings are pre-configured and can be used specifically on defined points in the area.

"Real-time Inversion/Rotation" with Video

Real-time inversion/rotation has been achieved not only with still images, but with video as well. Since adjustments of the observation angle are possible without moving the object, minute position and angle adjustments can be made with the mouse.

Inversions through the lens are quickly and correctly displayed.

Split-screen display

Split-screen display allows simultaneous comparisons of multiple images. The screen can be split into 2 (horizontally or vertically), 4, 9, and 16 screens.

Displaying the live image in one of the screens is effective for finding the observation point.

Recording with the Timer

Use the auto timer to take and save still photos at specified intervals without being in the room.

The lamp's energy-saving features allow you to set the timer without worrying about the life span of the lamp because the lamp is lit only when necessary.

Record Parameters with "User Mode"

A maximum of 10 types of parameters for camera settings can be registered and saved.

To later observe an object under identical conditions, simply use the front panel's user mode switch to select previously registered parameters as the camera's settings.

This is effective for analysis over an extended period of time.

6

Advanced Lighting Techniques

See the Unseen

Acquire various views of the object using our original optical adapter units. The unseen world will be revealed before your eyes.

Variable Angle Lighting Adapter

This adapter varies the lighting angle from vertical to lateral. There are many examples where invisible objects became visible by changing the lighting angle. It is possible to easily create an optimum lighting angle to match the same desired point on the object. This is effective for detecting scratches, burrs and blotches.



25 cent coin at 20x
[Vertical lighting]



25 cent coin at 20x
[Lateral lighting]

Diffuse Lighting Adapter

Produce diffuse and soft illumination in every direction by reducing the directionality of the lighting. This adapter reduces strong reflections so light hits evenly without direction, allowing clear observations of metallic surfaces without interferences.

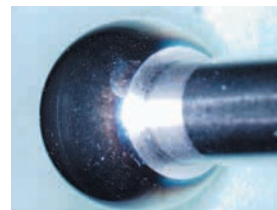

Ball joint at 40x
[Vertical lighting]

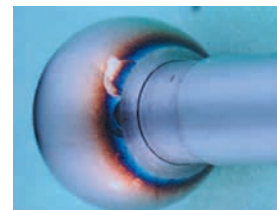

Ball joint at 40x
[Diffuse lighting]

Co-axial lighting adapter

This is an adapter that captures images, with regular reflections returned vertically, when light is parallel with the lens axis. In this case, the light is coming through the lens and not from a light ring. It is used for observing flat, intensely reflective or polished surfaces as an image that presents a great deal of information.

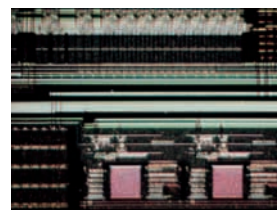

IC pattern at 1400x
[Dark field lighting]

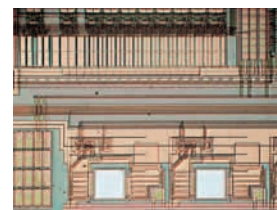

IC pattern at 1400x
[Bright field lighting using coaxial lighting]

Co-axial directional lighting adapter

We have taken normal co-axial lighting and created an original lighting adapter by installing Hirox's "directional" function. This adapter reproduces extremely microscopic surface shapes in addition to the standard high-resolution bright field images.



Bottom of a can at 250x
[Vertical lighting]



Bottom of a can at 250x
[Co-axial directional lighting]

Polarizing adapter

Light is comprised of both natural and polarized light. While natural light vibrates in all directions, polarized light vibrates in only one. This adapter includes a polarizing filter that utilizes the special properties of this light. Use this adapter to stop surface reflection and for color analysis of materials by application.

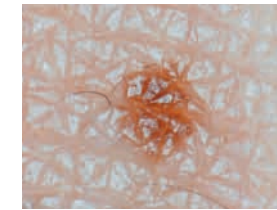

Freckle at 50x
[Lateral lighting]

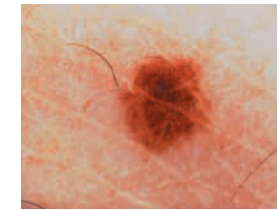

Freckle at 50x
[Polarized lighting]

Differential interference unit

Use the prism to separate linear polarized light into two rays of polarized light, which penetrate the object. Then detect the shading interference occurring in response to the phase contrast from the difference of the optical path of the polarized light rays. Observe the height difference to a few hundred nanometers of a single shading streak for the brightest and darkest parts depending on the wavelength of the optical path difference. This is effective in a general bright field with gentle waves where contrast is hard to acquire.



Indentations of LCD conduction poles
at 200x
[Bright field lighting]



Indentations of LCD conduction poles
at 200x
[Differential interference]

Backlighting unit

This unit is useful for observing light-transmitting subjects or accurately detecting edges. The backlighting unit allows observation of combined light, such as light and dark areas, and diffusion.

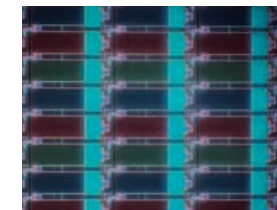

LCD panel at 700x
[Vertical lighting]



LCD panel at 700x
[Backlighting]

Variable transmission light unit

This unit uses Koehler illumination. Lighting an object using collimated lighting with the Koehler illumination is effective for subjects that transmit light and allows acquisition of vivid and high contrast images. Especially if the object is small and difficult to see with transmission, high contrast observations can be made with minute transmission interference lighting by sliding the difference filter. It is effective for observing microorganisms.

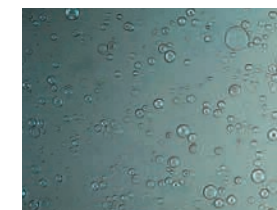

Lactic bacterial at 3500x
[Variable transmission light]

Polarized transmission unit

Polarized transmission lighting is used as a lighting method to form an image with strong light for objects through which light is difficult to transmit. The chance of seeing inside permeable objects (comparatively large objects) and the direction of organization that under normal lighting could not be seen, are observable in color. This unit can also be used in combination with the variable transmission light unit for classifying microorganisms.

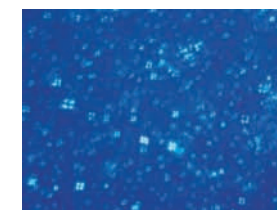

Lactic bacterial at 3500x
[Polarized transmission lighting]

7 Different Applications

Sample Images

The KH-7700 meets the needs of diverse technology and new materials development. Here is just a taste of the broad capabilities of the KH-7700.

Semiconductors/ SMT

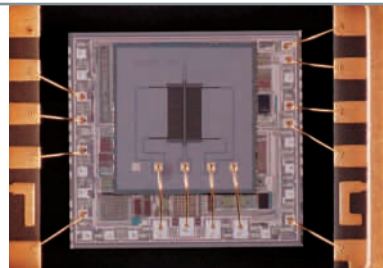

IC package at 100x

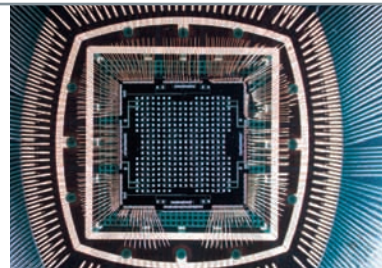

IC package at 50x

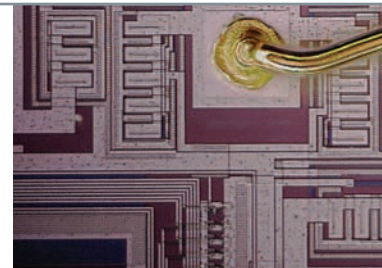

IC package at 1000x

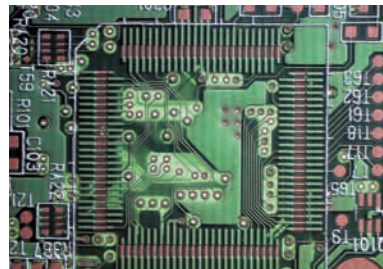

Board for control devices taken at macro



0402 laminated ceramic pad at 200x



QFP contacts at 200x

Automotive/ Nondestructive



Wire bonding at 1000x

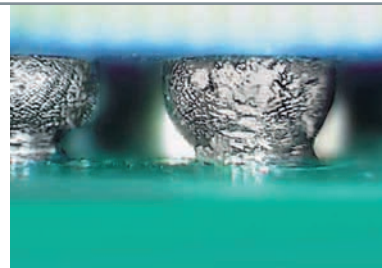

BGA ball at 150x

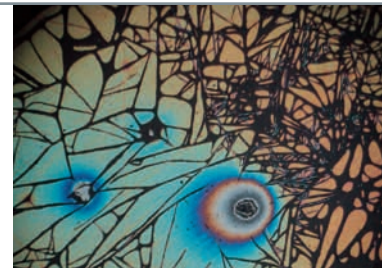

Carbon-based film at 1000x

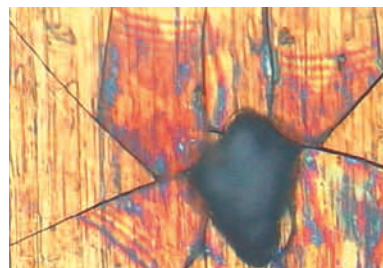

Inside of a cylinder at 1400x

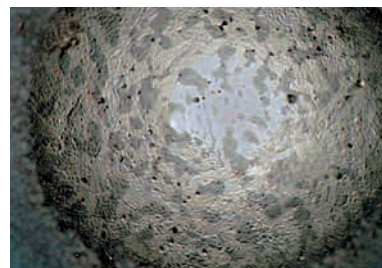

Flip chip ball at 1000x



Metallic organization at 2000x

Machinery/ optical materials/ judgment



Man-made diamond at 150x

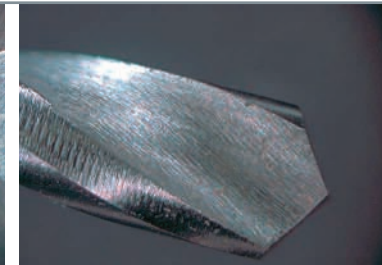

Drill at 200x

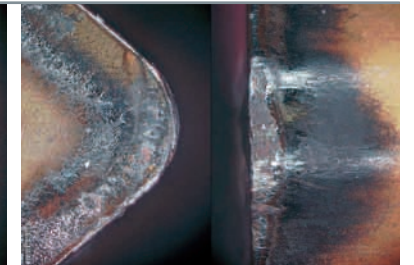

Chip bite at 60x, split-screen, compared abrasion

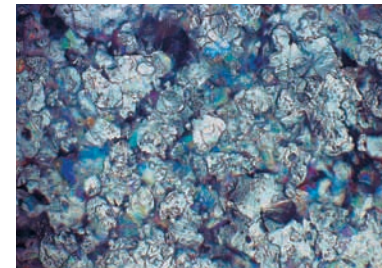

Silver coating of a cellular phone at 1400x



Solder fillet of a QFP contact at 300x

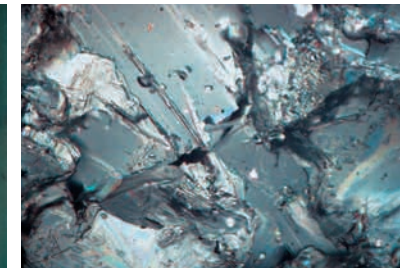

Single crystal superconductor at 1000x

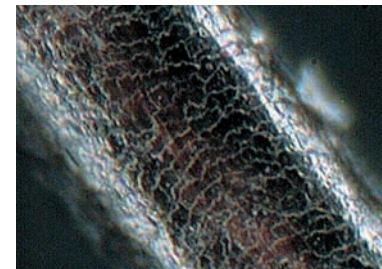

Hair cuticle at 3500x

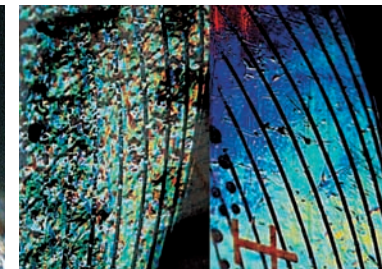

Counterfeit money at 300x



Bullet, impression after use, at 50x

Organisms/Medical



Mouse fetus 10.5 days after conception at 50x



A fruitfly at 100x

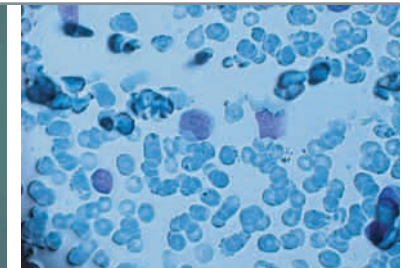

Streptococcus at 2800x

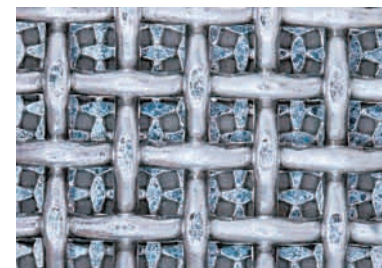

Precision filter at 500x

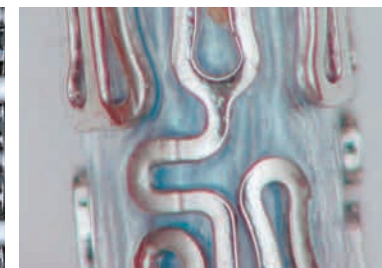

Stent at 150x



Protein crystals at 100x

8

System Configuration

System Configuration

An extensive lens adapter lineup and the connectivity of peripheral devices make it easy to build customized configuration.

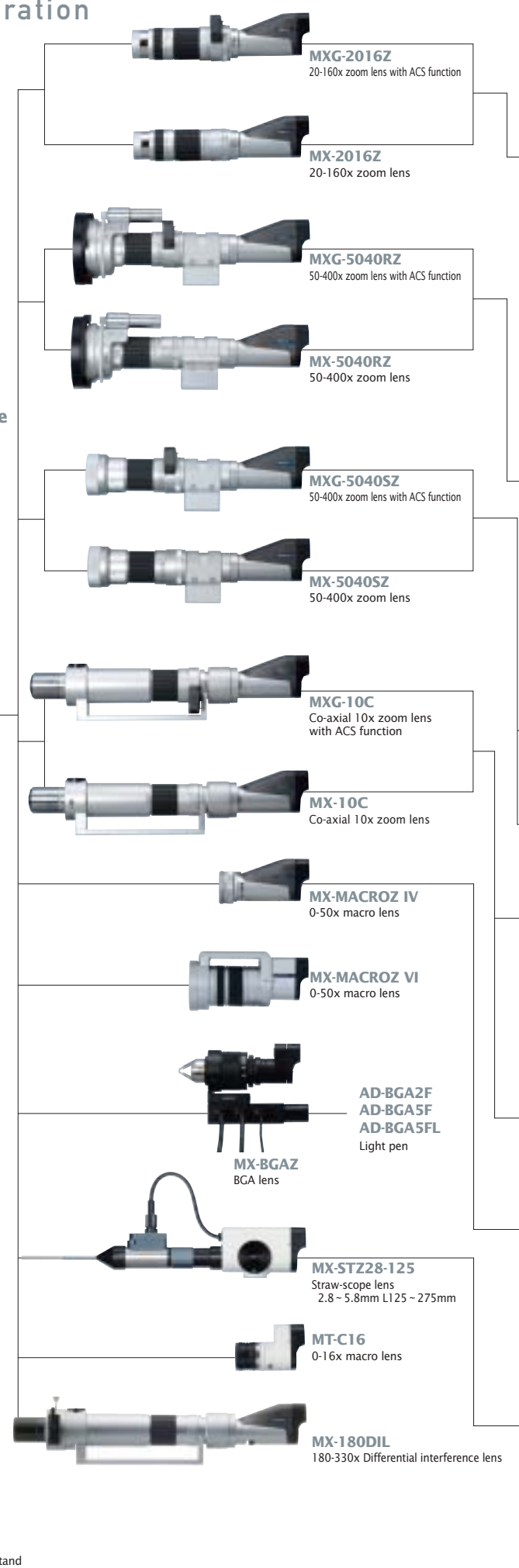
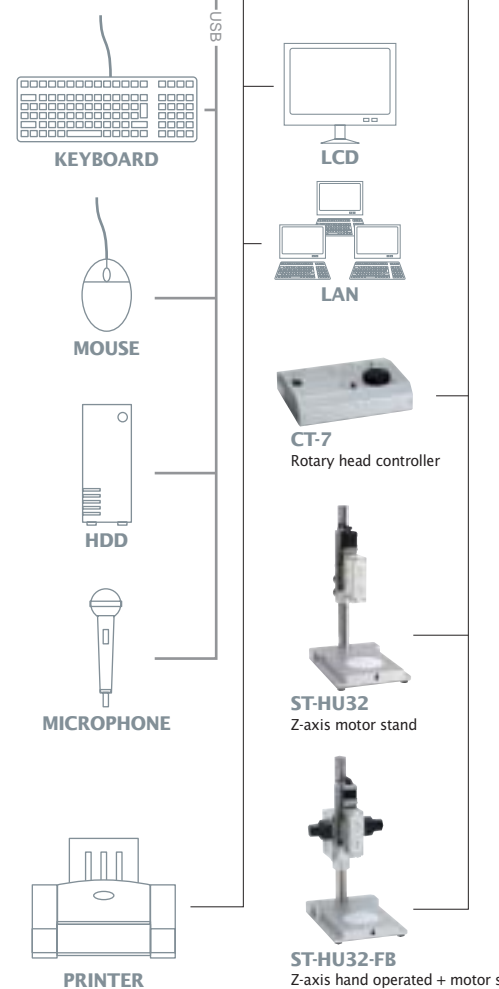

AD-2016H Non-contact adapter	AD-2016S Variable Angle Lighting Adapter	AD-2016SV Contact adapter	AD-2016LOW Low magnification adapter	AD-2016HI High magnification adapter	AD-2016SL Laser slit light adapter	AD-2016LOWR Low magnification rotary head
AD-2016L(S/L) Side view adapter	AD-2016D Diffuse lighting adapter	AD-2016HIS High magnification variable angle adapter	AD-2016P Polarizing adapter	AD-2016C Co-axial lighting adapter	AD-2016RLD Diffuse lighting adapter for rotary head	AD-2016RLM Rotary head

AD-5040HS Non-contact adapter	AD-5040DS Diffuse lighting adapter	AD-5040SVS Contact adapter	AD-5040LOWRS Low magnification rotary head	AD-5040HIRS High magnification rotary head	AD-5040RVS Variable angle rotary head	AD-5040RVD Diffuse lighting adapter for rotary head
AD-5040LWS Low magnification adapter	AD-5040HIS High magnification adapter	AD-5040SS Variable angle lighting adapter	AD-5040SHIS High magnification variable angle adapter	AD-5040CS Co-axial lighting adapter	AD-5040PS Polarizing adapter	AD-5040SLS Laser slit light adapter

AD-5040SD Snap-on adapter	AD-5040H Non-contact adapter	AD-5040LOW Low magnification adapter	AD-5040HI High magnification adapter	AD-5040SHI High magnification variable angle adapter
------------------------------	---------------------------------	---	---	---

AD-10S Directional lighting adapter	AD-10P Polarizing adapter	AD-10R Optical rotary adapter
--	------------------------------	----------------------------------

OL-35 35-350x object lens	OL-70 70-700x object lens	OL-140/OL-140 140-400x object lens	OL-350 350-3500x object lens	OL-700/OL-700 700-7000x object lens
------------------------------	------------------------------	---------------------------------------	---------------------------------	--

NR-405-M4 Fiber ring light for MX/MACROZ IV
--

AD-STL28-125 Side view adapter
Other 3.0 - 6.0mm L125 - 275mm

CT-1 Rotary head controller

*Controller for the MXG-5040RZ, MX-5040RZ, AD-2016LOWR, AD-2016RLM

NR-405-OL Fiber ring lighting for MX and MXG-10C

STAND						
ST-HU2 High precision stand	ST-HE Standard stand	ST-HN Standard stand II	ST-AU Angle stand	ST-HL Large size stand	ST-HK Stand for BGA	
STAGE / UNIT						
AS-XYB XYZ stage for backlight use	AS-XY XY stage	AS-XYL Large size sliding stage	AS-BH BGA substrate holder	AS-B Backlighting unit	AS-BP Crystal transmission observation unit	AS-DFR Variable transmission light unit

mark indicates options.



9

User Friendly

Easy on the mind, the body and the environment

The concept of "Comfortable Observation" has been a principle at Hirox since our founding. Hirox has strived to design products that significantly reduce fatigue and stress to achieve "Ease of Use". Our investigations into the comfortable operation of our digital microscope means you get image performance that provides "images that are visually stimulating" and "lifelike video images".

The introduction of the digital microscope made peering through instruments to observe objects by putting the image on a monitor. Ever since, we have reduced eye, neck and back strain. Moreover, since many people can simultaneously view the image, magnified observation is no longer a solitary operation.

We at Hirox believe that the new KH-7700 digital microscope contributes to the inexhaustible human spirit of inquiry, curiosity, and free thinking.

Even Easier Magnified Observation

The machine has morphed from simply facilitating observation into a close partner of the user. It's easy to use, ergonomically designed, and of course environment friendly.

[Compliance with the RoHS Environmental Protection Program]

Hirox is compliant with the [RoHS Directives] based on the fundamental principals and plan stated below. These directives regulate goods manufactured after October 2006 that use hazardous substances that have an adverse affect on the environment or human life.

■Fundamental Principles: Recognizing that preservation of the environment is the greatest problem facing the human race, Hirox is working with all of its divisions to reduce its environmental impact.
 ■Plan: In order to reduce the environmental impact of all manufacturing and consumption practices related to the production and sale of our digital microscopes as well as future products and services, Hirox is pursuing an environmental management program striving to achieve harmony with the environment.

RoHS Directive: Known as the "Directive for the reduction of the use of certain hazardous substances in electrical and electronic equipment." It is effective in all areas of the EU. The use of the following six hazardous substances in electrical and electronic equipment is regulated: Pb (lead), Cd (cadmium), Hg (mercury), hexavalent chrome, PBB (polybrominated biphenyl), and PBDE (polybrominated diphenyl).

10

Specification

Specifications

Basic Functions

Camera	Imaging device	1/1.8" 2.11 megapixel CCD
	Scanning Mode	Progressive scan
	Total number of pixels Approx.	2.11 megapixels 1688 (H) x 1248 (V)
	Number of effective pixels Approx.	2.01 megapixels 1688 (H) x 1236 (V)
	Frame rate	15 fps, double buffer method
	Electronic shutter	AUTO(1/15 ~ 1/15000), 1/15000, 1/8300, 1/5800, 1/4400, 1/3600, 1/2500, 1/1000, 1/500, 1/250, 1/125, 1/60, 1/30, 1/15
	Slow shutter	1/7.5, 1/4, 1/2, 1, 2, 4, 8, 16
	Gain	AUTO.MANUAL.OFF
LCD monitor	White balance	AUTO, MANUAL (R, B)
	Image adjustment	Gamma correction, color correction, edge enhancement
	Display size	15" LCD color monitor
	Pixel pitch	0.1905mm(H)x0.1905mm(V)
	Number of pixels	1600(H)x1200(V)
	Brightness	200cd/m2(typ.)
Light source	Contrast ratio	500:1(typ.)
	Viewing angle	170° [H], 170° [V] (type.)
	Lamp	60 W metal halide lamp
	Lamp life	4000 H (average)
Output	Color temperature	5500 ± 100K
	Analog RGB output	UXGA, SXGA, XGA
	Printer output	USB2.0(B type), PictBridge
	LAN	10BASE-T/100BASE-TX/1000BASE-T
	External terminal	Round 6 pin
	ACS terminal	Round 10 pin
Input	Remote control	RS-232C connector
	Mouse and keyboard input	USB 2.0 (Type A)
	USB ports	USB 2.0 (Type A) x 6
Record	Microphone input	MIC jack
	Recording media	160 GB hard disk, CD-R/RW, DVD±R/+R DL/±RW/-RAM
	Still image format	Exif-TFF [non-compressed], BMP [non-compressed], Exif-JPEG [compressed]
	Compression mode	JPEG [4 levels]
	Number of recorded still pixels	Standard: 1600 x 1200, 1280 x 960, 1024 x 768, 800 x 600, 640 x 480, 320 x 240 High resolution: 6400x4800, 4800x3600, 3200x2400, 2400x1800
	Video image format	AVI [non-compressed]
Number of recorded video pixels		1600x1200(7.50FPS), 1280x1024(7.50FPS), 1024x768(15.00FPS), 800x600(15.00FPS), 640x480(15.00FPS)
Image adjustment		Contrast, edge enhancement, noise reduction, binarizing
Rated voltage		AC100 ~ 240V, 50/60Hz
Power consumption		250W
Ambient temperature		5° C to 40° C (No freezing or condensation)
Storage temperature		-15° C to 50° C (No freezing or condensation)
Relative humidity		25 to 85% RH (No condensation)
Atmosphere		Corrosive gas prohibited
Weight	Main Unit	Approx. 12 kg
	Camera	Approx. 1 kg
Size	LCD shut	417.4(W)x154(H)x343.1(D)mm
	LCD open	417.4(W)x429.6(H)x343.1(D)mm

Other functions

Observation settings	Camera preview
	Individual camera preview
	Camera image settings
	Save camera settings
	Auto white balance
Observation	Focus control
	Focus indicator
	Multi focus
	Lamp ON/OFF
	Zoom ON/OFF
	Anti-halation
	High resolution image capture
	High resolution settings [4 levels]
	Grid settings
	Lens adapter settings
	Brightness settings [0-127 levels]
	Gamma correction
	Contrast settings
	Halation mitigation settings
	Hue correction [7 levels], chroma correction setting [5 levels]
Edge filter size setting [4 levels]	
Edge strength setting [OFF, 7 levels]	
Edge circuit ON/OFF	
Chroma ON/OFF	
Comparing	Comparison of image synthesis
2D Measurement	ACS compatible
	High resolution measurement
	Auto calibration
	2 point measurement, angle, radius, area, etc.
	Auto count
3D Observation	Scale display
	List display
	Handy Synthesis
	Multi focus [fully automatic synthesis]
	Multi focus [semi-automatic synthesis]
3D Profile	Multi focus [manual synthesis]
	Lighting
	2D and 3D display
	Noise reduction
	ACS compatible
Screen splitting	Focus control [auto focus position]
	Focus control [display height information in real-time]
	Focus point memory
	Balloon indication [height measurement]
	Selection profile [height, length, angle, etc.]
	Wireframe display [can display height information]
	False color display [can display height information]
	Volume and area measurement
Display	Top/bottom, right/left, 4/9/16 window splitting
	Turning over, ±90° rotation
Record	Grid, scale display
	Display date
	Comments, graphics display
Other	Display image properties
	Video and still image settings
	Video and still image archiving
	Still image timer capture
	Library management
Other	Soft keyboard ON/OFF
	Easy report writer
	Macro control
	Multi-user settings
	System settings
	Time setting
	Volume and luminance adjustment
	Network settings
	Function key
	Settings manager
Language setting	
Help	
Version information	
Print	